

KAWASAKI GAS TURBINE GENERATOR SETS

Kawasaki Heavy Industries, Ltd.

global.kawasaki.com/en/energy/equipment/gas_turbines/index.html

Kawasaki Heavy Industries, Ltd. Tokyo Head Office
Tel: +81-3-3435-2579 Fax: +81-3-3435-2592

Kawasaki Machine Systems, Ltd. (Far East Asia)
Tel: +81-3-3435-2977 Fax: +81-3-3435-2592

Kawasaki Machine Systems, Ltd. Korea Branch
Tel: +82-2-527-2201 Fax: +82-2-527-2205

Kawasaki Gas Turbine Asia Sdn Bhd (KGA)
Tel: +60-3-7846-2882 Fax: 60-3-7848-3093

Kawasaki Gas Turbine Europe GmbH (KGE)
Tel: +49-6172-7363-0 Fax: 49-6172-7363-55

Kawasaki Gas Turbine Service RUS LLC
Tel: +7-423-262-0201 Fax: +7-423-262-0202

Kawasaki Heavy Industries (Thailand) Co., Ltd.
Tel: +66-2-163-2840 Fax: +66-2-163-2841

Kawasaki Gas Turbine Asia Sdn Bhd Jakarta Representative Office
Tel: +62-21508-15125

Kawasaki Gas Turbine Europe GmbH, Romanian Representative Office
Tel: +40-374 645915 Fax: +40-374 094901

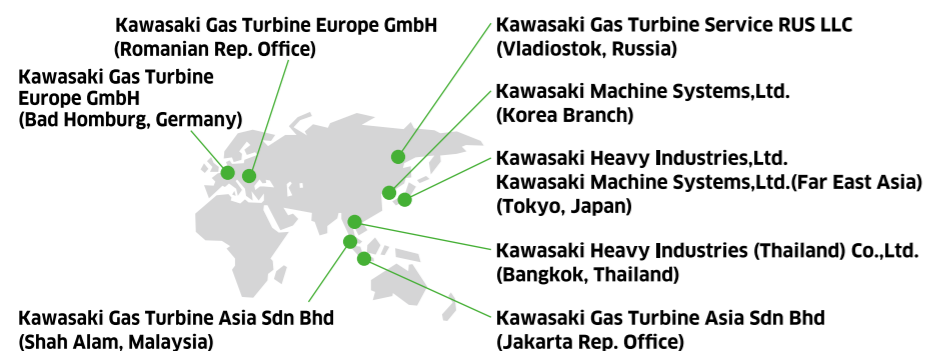

ISO 9001 / ISO14001 Certified

The Energy System Division is located at Akashi Works in Japan. It designs and manufactures the Gas Turbine Co-generation System, and is certified for ISO 9001, the international standard of quality assurance, and ISO 14001, the international standard for environmental management.



L30A





L30A Gas Turbine



V2500 Turbofan
(International Aero Engines AG)



Boeing 787



Trent1000 Turbofan
(copyright Rolls-Royce PLC)



BK117 C-2 Type



R142A Subway Car For NYC



Industrial Robot



Jet Ski® ULTRA260X



Ninja H2



A Lime / Limestone Gypsum
Flue Gas Desulfurization Plant



Wind Turbine Generation Plant



Akashi Kaikyo Bridge



Wheel Loader 92ZV-2



High Speed Train "efSET"



Marine Steam Turbine
(UA-Type)



Submarine



Two-Stroke Marine
Diesel Engine



Gas Engine



LNG Carrier

KAWASAKI HEAVY INDUSTRIES, LTD. An Integrated Engineering Manufacturer Spreading Its Interests by Land, Sea and Air.

Kawasaki Heavy Industries, established in 1878, has a history of more than 140 years of manufacturing integrated engineered products. Our business has expanded to include the manufacturing of ships, railway rolling stock, aircraft, gas turbines, many types of industrial plants, steel structures, general machinery, and motorcycles. Our products are found on the land, in the sea and in the air. By constant attention to production efficiency and through exclusive technologies developed internally, we are continuing to develop additional technologies related to transportation innovations, national land and marine resources development, space exploration development, environmental controls, new energy development, and biotechnology development. The range of our technologies is greatly expanding to encompass large, diverse projects.



Kawasaki Gas Turbine places importance on "Efficient Energy Use", "Eco-friendly" and "Reliable Product Care for Total Life Cycle" as a philosophy of our products. To enhance this philosophy, we have introduced a title for our products....."GREEN Gas Turbines".

" Get Reliable Eco-friendly Energy Now "

INDEX

- Introduction 1 . 2
- History and Order Record of Kawasaki Gas Turbines 3 . 4
- Baseload Model 5 . 6
- M1A Series Gas Turbine Generator Specifications 7 . 8
- M5A Series Gas Turbine Generator Specifications 9
- M7A Series Gas Turbine Generator Specifications 10
- L20A Series Gas Turbine Generator Specifications 11
- L30A Series Gas Turbine Generator Specifications 12
- Standby Model Introduction 13
- Standby Model (GPS Series) 14
- Mobile / Trailer Model (MGP / TGP Series) 15. 16
- Kawasaki Techno-Net 17
- Installation Examples 18

History and Order Record of Kawasaki Gas Turbines

History

- 1943 Completed the first Gas Turbine engine for aircrafts in Japan
- 1952 Started overhauling jet engines
- 1972 Started development of industrial Gas Turbine**
- 1974 Completed first S1A-01 type : 200 kW Gas Turbine
- 1977 First Kawasaki Gas Turbine genset : 200kW delivered
- 1979 First genset to overseas customer delivered
- 1984 First Kawasaki Gas Turbine Co-generation system 2x1.0MW delivered
- 1985 Accumulated sales of 1,000 engines
- 1988 1.5 MW M1A-13 type Gas Turbine introduced
- 1993 5.5 MW M7A-01 type Gas Turbine introduced
- 1995 1.5 MW M1A-13D Dry Low NOx type Gas Turbine introduced
- 1998 Overseas sales and service affiliates were established in the U.S., Germany and Malaysia
- 1999 6.5 MW M7A-02 type Gas Turbine introduced
5.5 MW M7A-01D Dry Low NOx type Gas Turbine introduced
Accumulated delivery of 5,000th engine
Experimental ceramic Gas Turbine completed and achieved the world record of 42.1% simple cycle efficiency for the 300kW class
- 2000 18 MW L20A type Gas Turbine introduced
- 2001 Akashi Works NO.4 Power Plant GPC180D : 17.6 MW commercial start-up
- 2005 Start-up Akashi Works Energy Center, which comprises 24.7 MW Combined Cycle and 7.8 MW Flexible Heat and Power Gas Turbine Power Plant
- 2006 7.7 MW class M7A-03 type Gas Turbine introduced
- 2007 Received the 100th Order of the M7A Series
- 2009 15ppm (NOx) M7A-03D type Gas Turbine introduced
- 2010 Accumulated sales of 10,000 engines**
1.7 MW class M1A-17 type Gas Turbine introduced
- 2011 9ppm (NOx) M7A-03D type Gas Turbine introduced
- 2012 30 MW L30A type Gas Turbine introduced
- 2014 30 MW L30A Low-NOx hydrogen combustion type Gas Turbine launched
- 2015 Demonstration test of Low-NOx Gas Turbine using mixed hydrogen combustion system
- 2017 5MW M5A-01D type Gas Turbine introduced

● Accumulated Number of Engine sales all over the world

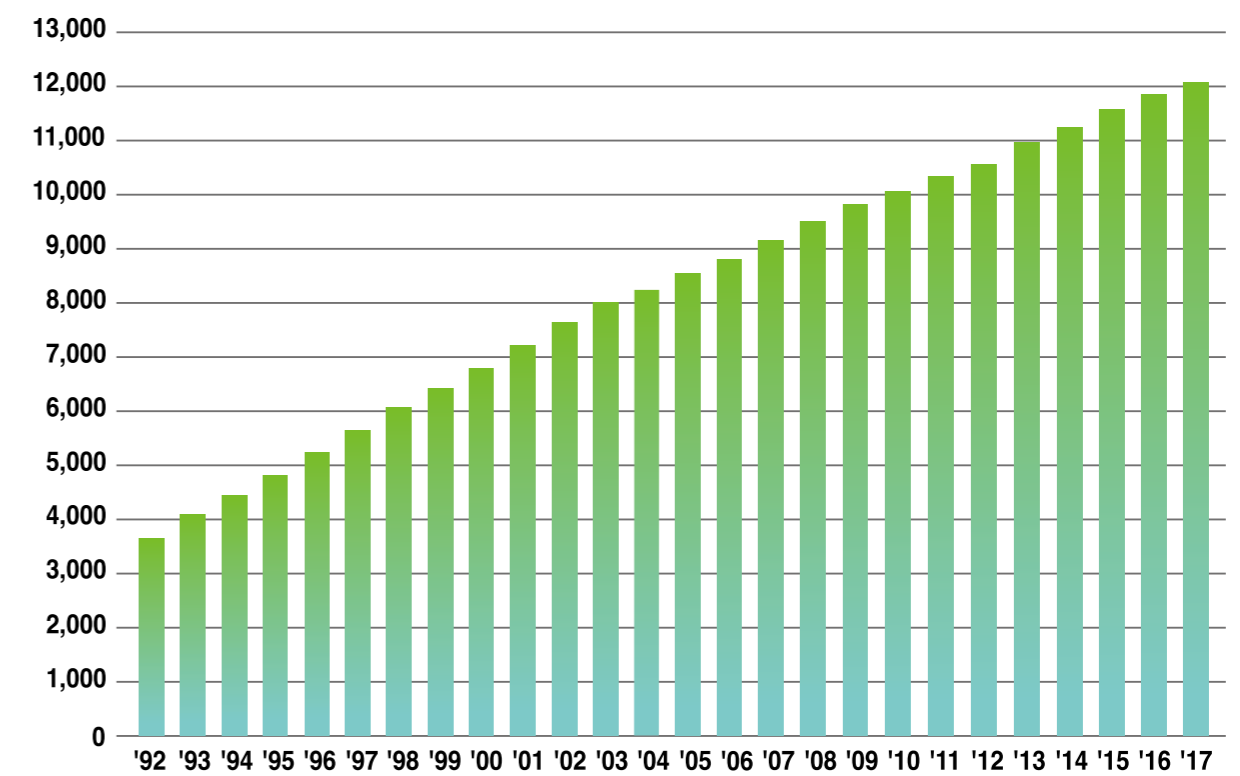

Baseload Model

Basic Specifications

Engine Series	M1A Gas Turbine Series						
	M1A-13A	M1A-13D	M1A-17	M1A-17D	M1T-13A	M1T-13D	
Gas Turbine Model	GPB15	GPB15D	GPB17	GPB17D	GPB30	GPB30D	
Gas Turbine Generator Model							
Maximum Continuous Electric Output	kWe	1,490	1,490	1,810	1,810	2,930	2,930
Heat Rate	kJ/kWe-hr	14,880	15,030	12,830	12,830	15,100	15,240
Thermal Efficiency	%	24.2	24.0	28.1	28.1	23.8	23.6
Exhaust Gas Temperature	°C	521	531	522	522	521	531
Exhaust Gas Mass Flow	x10 ³ kg/hr	29.1	28.8	29.1	29.1	58.2	57.6
NOx (O ₂ : 15%)	ppm	-	25	-	9 / 15	-	25
Approximate Package Dimension (L,W,H)	m	5.3 x 1.65 x 2.35		6.0 x 1.85 x 2.55		6.0 x 2.4 x 2.8	
Approximate Package Weight (dry)	x10 ³ kg	11		11.5		22	

Note: Mark "D" after Gas Turbine Model stands for Dry Low Emission
Condition : ISO Rating 1. Inlet Air Temperature : 15°C 2. Atmospheric Pressure : 101.3 kPa 3. Inlet / Exhaust Pressure Losses : No Duct Loss
 4. Fuel Type : Natural Gas (100% CH₄) 5. LHV of Fuel : 35.9 MJ/Nm³

The Kawasaki GPB Series is designed for baseload applications, for both parallel operation with the grid and island mode operation. In addition, the Kawasaki GPB Series are able to operate in Co-generation service, with automatic operation capability supplying both electricity and heat (steam, hot water, direct heat) by collecting waste heat with a heat recovery steam generator (HRSG), heat exchanger, or dryer, and in Combined Cycle with a steam turbine generator. With high total thermal efficiency, the Kawasaki GPB Series are capable of highly efficient operation.

Gas Turbine Illustration

Centrifugal Compressor for M1A Gas Turbine Series

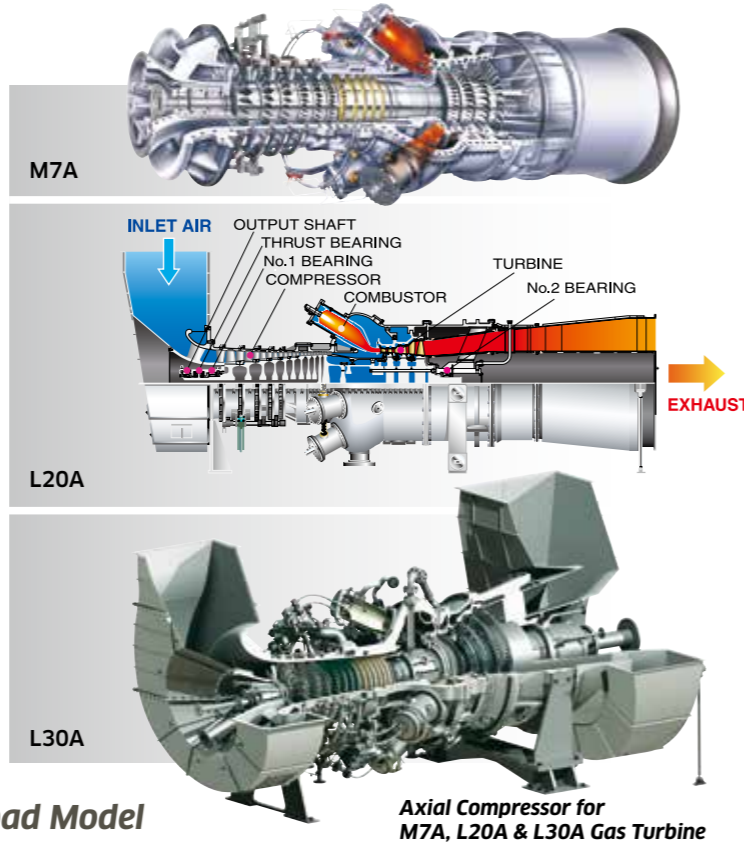
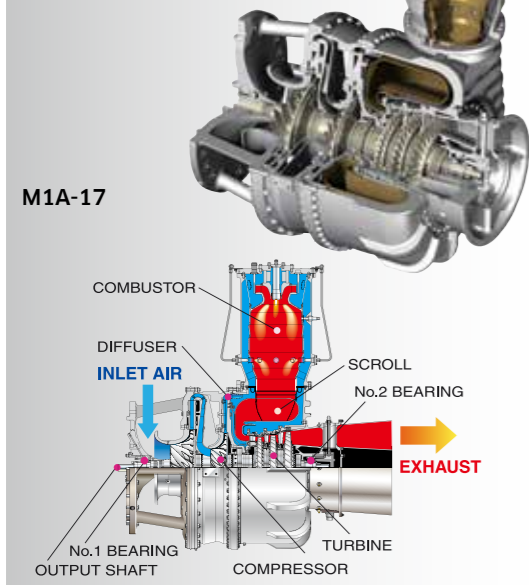

Features of Kawasaki Gas Turbine Baseload Model

- Self-developed Gas Turbine Fully Made in Japan**
- Various lineup and reliable installation records all over the world.
- Very High Durability Industrial Gas Turbine**
- Removable Combustor and Inspection holes on Turbine make the inspection easier.
- Eco-friendly**
- Kawasaki Gas Turbine has DLE (Dry Low Emission) Combustor. DLE Combustor reduces NOx significantly and cleans exhaust gas.
- Various Type of Fuel Applicable**
- Whichever fuel, city gas, LNG, Kerosene, light oil, A-type heavy oil, off gas can be selected.
- Reliable After Service**
- Reliable after service system is available, which satisfies customer's requirement with spare engines and parts supply system supported by well experienced service persons.

M5A Gas Turbine Series	M7A Gas Turbine Series		L20A Gas Turbine Series	L30A Gas Turbine Series
M5A-01D	M7A-03	M7A-03D	L20A	L30A
GPB50D	GPB80	GPB80D	GPB180D	GPB300D
4,710	7,800	7,800	18,420	34,380
11,030	10,730	10,730	10,530	8,930
32.6	33.6	33.6	34.2	40.3
511	523	523	542	502
62.6	97.9	97.9	215.3	333.3
25	25	9 / 15	15	15
8.7 x 2.6 x 3.5	11.5 x 2.8 x 3.6		17.2 x 3.5 x 3.4	21.6 x 6.2 x 5.7
55	58		131	250

M5A : The Standard Solution for Power Generation

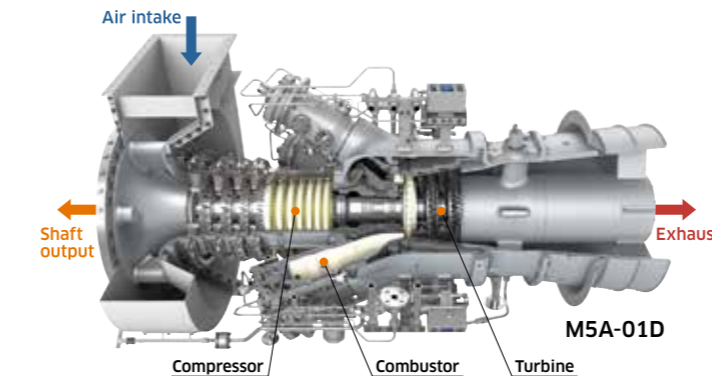

GPB50D gas turbine generator package offers high efficiency 5MW power utilizing Kawasaki M5A-01D gas turbine developed with the latest and proven technologies. Its high performance provides the optimal solution for power generation and co-generation. GPB50D's compact package design is also perfect for renewal projects of existing facilities.

M7A : The Leading Edge - Single Digit Super Low NOx emission Available !

In 2011, Kawasaki introduced to the market the newest combustion system which realized Single Digit Super Low NOx emission with the M7A-03 gas turbine engine.

In many countries and regions, environmental protection requirements and regulations are getting tighter and tighter. In order to meet such requirements and regulations, Kawasaki has developed its new Single Digit Super Low NOx combustion system. Furthermore, Kawasaki will apply this technology subsequently to other engines of its fleet to give the market greater satisfaction and contribute to environmental burden reduction.



L30A : The World's Most Efficient 30MW Gas Turbine

In June 2012, Kawasaki introduced a new gas turbine named L30A as a flagship model of its industrial gas turbine fleet. Based on Kawasaki's well proven design technology, this machine is said to be the most efficient 30MW class gas turbine in the world, combined with very low emission output, high reliability and availability. In addition, with its modular system design, the L30A has realized excellent on-site maintainability. The L30A is able to provide a highly flexible solution for power generation and mechanical drive applications.

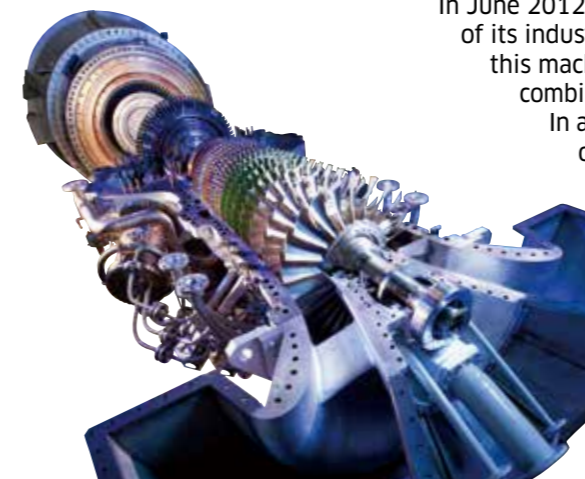

Ultimate Solution
40.3%

M1A Series Gas Turbine Generator Specifications

Site Condition for Normal Perfor

Elevation above sea level : 0 m
 Inlet Air Temperature : 15 °C
 Inlet Air Pressure Loss : 0.98 kPa
 Exhaust Gas Pressure Loss : 2.45 kPa
 LHV of Natural Gas Fuel : 35.9 MJ/Nm³ (100% CH₄)

Typical Steam Condition

Steam Pressure : 0.83 MPaG
 Steam Temperature (Saturated) : 177 °C
 Feed Water Temperature : 80 °C
 Blowdown from HRSG : 0 %

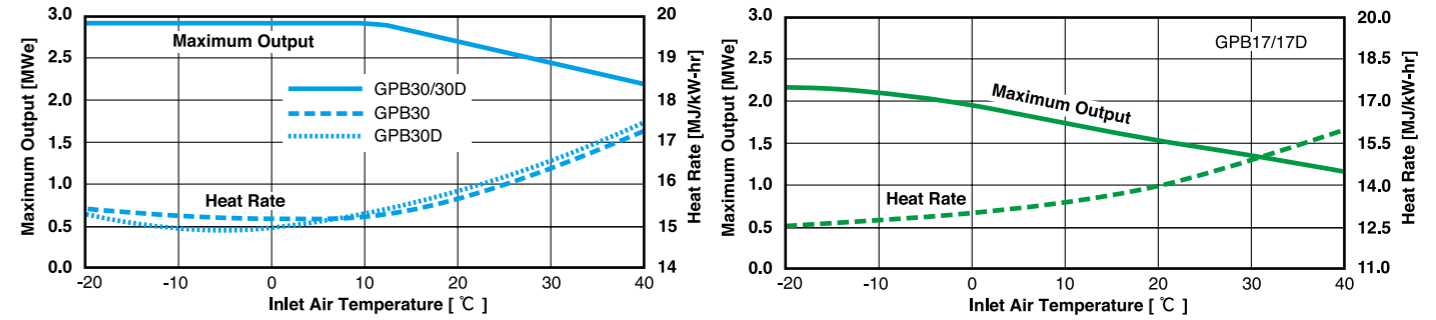
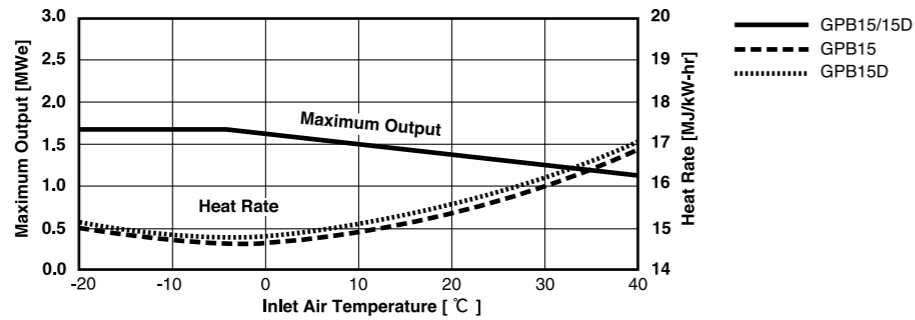

Gas Turbine Model	M1A Gas Turbine Series											
	M1A-13A			M1A-13D			M1T-13A			M1T-13D		
Gas Turbine Generator Model	GPB15			GPB15D			GPB30			GPB30D		
Partial Load @ AT 15 °C %	100	75	50	100	75	50	100	75	50	100	75	50
Electric Output kWe	1,450	1,090	730	1,450	1,090	730	2,850	2,140	1,430	2,850	2,140	1,430
Heat Rate kJ/kWe-hr	15,130	16,500	19,750	15,280	16,660	19,900	15,350	16,800	20,190	15,510	16,960	20,370
Exhaust Gas Temperature °C	524	441	368	534	448	374	523	441	370	534	449	375
Exhaust Gas Mass Flow x10 ³ kg/hr	28.8	29.2	29.6	28.5	29.0	29.4	57.6	58.5	59.2	57.0	58.0	58.8
HRSG Steam Output (Typical*1) x10 ³ kg/hr	5.0	3.8	2.8	5.1	3.9	2.8	9.9	7.6	5.6	10.2	7.8	5.7
Total Thermal Efficiency %	79.2	73.6	65.4	79.7	74.2	66.1	78.8	73.3	65.2	79.3	73.9	65.9
Inlet Air Temperature °C	0	15	40	0	15	40	0	15	40	0	15	40
Maximum Continuous Electric Output kWe	1,620	1,450	1,120	1,630	1,450	1,116	2,945	2,850	2,210	2,950	2,850	2,190
Heat Rate kJ/kWe-hr	14,690	15,130	16,880	14,810	15,280	17,140	15,150	15,350	17,209	15,290	15,510	17,475
Exhaust Gas Temperature °C	516	524	547	526	534	559	485	523	547	492	534	559
Exhaust Gas Mass Flow x10 ³ kg/hr	30.9	28.8	25.2	30.7	28.5	24.8	62.1	57.6	50.3	61.7	57.0	49.7
HRSG Steam Output (Typical*1) x10 ³ kg/hr	5.2	5.0	4.8	5.3	5.1	4.9	9.4	9.9	9.5	9.6	10.2	9.7
Total Thermal Efficiency %	76.5	79.2	82.4	77.8	79.7	82.8	73.4	78.8	82.1	75.7	79.3	82.5

Gas Turbine Model	M1A Gas Turbine Series					
	M1A-17			M1A-17D		
Gas Turbine Generator Model	GPB17			GPB17D		
Partial Load @ AT 15 °C %	100	75	50	100	75	50
Electric Output kWe	1,755	1,315	875	1,755	1,315	875
Heat Rate kJ/kWe-hr	13,120	14,370	17,320	13,120	14,370	17,320
Exhaust Gas Temperature °C	526	443	377	526	443	377
Exhaust Gas Mass Flow x10 ³ kg/hr	28.8	29.4	29.9	28.8	29.4	29.9
HRSG Steam Output (Typical*1) x10 ³ kg/hr	5.0	3.9	2.9	5.0	3.9	2.9
Total Thermal Efficiency %	80.4	75.4	67.5	80.4	75.4	67.5
Inlet Air Temperature °C	0	15	40	0	15	40
Maximum Continuous Electric Output kWe	2,050	1,755	1,305	2,050	1,755	1,305
Heat Rate kJ/kWe-hr	12,460	13,120	14,930	12,460	13,120	14,930
Exhaust Gas Temperature °C	511	526	560	511	526	560
Exhaust Gas Mass Flow x10 ³ kg/hr	31.5	28.8	24.4	31.5	28.8	24.4
HRSG Steam Output (Typical*1) x10 ³ kg/hr	5.2	5.0	4.7	5.2	5.0	4.7
Total Thermal Efficiency %	78.6	80.4	83.0	78.6	80.4	83.0

M1A/T-13 Series Standard Package Configuration

M1A-13A Gas Turbine

- Industrial Single-Shaft
- Rotor Speed : 22,000 rpm

M1T-13 Gas Turbine

- Twin M1A GT with Combined Gear Box

Compressor

- 2 Stage Centrifugal
- Pressure Ratio : 9.4 (-13A), 9.6 (-13D)
- IGV (-13D Option)

Combustor

- Single Can Combustor
- Single Ignition
- Conventional Diffusion (-13A)
- Steam Injection to Diffusion Combustor (-13A Option)
- Dry Low Emission (DLE) (-13D)
- Applicable Fuel : Natural Gas, Diesel, Dual Fuel (-13A)

Turbine

- 3 Stage Axial Turbine

Coupling Shaft & Cover

- Flexible Coupling with Shear Pin and Cover

Reduction Gear Box

- Epicyclic (M1A), Parallel (M1T)
- Output Speed : 1,500 / 1,800 rpm (50/60 Hz)

Starting and Turning Motor System

- Various Frequency Drive (VFD)
- (Option : Air Starter, DC Motor)
- Turning Motor

Lube Oil System

- Lube Oil : Synthetic Ester Oil
- Turbine Driven Main Lube Pump
- Pre-Post Lube Pump
- Air Cooled Oil Cooler with Temp. Control Valve
- Water Cooled (Option)
- Integral Oil Reservoir : 210 liter (GPB15) : 160 liter (GPB30)
- Simplex Filter (Option: Duplex Type)

Generator

- Continuous Duty Rating
- Air Cooled Open Drip-Proof Construction
- Water Cooled (Option)
- 3 Phase, 3 Wire (Option 4 Wire)
- Standard Voltage : 3.3 kV, 6.6 kV
- Power Factor : 90% (Option 85%, 80%)
- Bearing : Ball (Roller) Bearing
- Lubrication : Grease Pack
- Exciter : Diverted Field Brushless (Option PMG)

Enclosed Package

- Carbon Steel Common Base Frame
- Outdoor Carbon Steel, Acoustic Enclosure
- Noise Level : 85 dBA at 1 m to the side of Enclosure
- Forced Ventilation Fan with Filter and Inlet Screen
- Maintenance Stage, Ladder, Beam (Option)

Intake Silencer & Filter

- Painted Carbon Steel (Outer Skin and Structure)
- 2 Stage Filter with Insect Screen
- Pulse Self Cleaning Filter (Option)
- Noise Level : 85 dBA in front of Filter

Exhaust Silencer and Stack (Option)

- Controls
- Microprocessor Based Programmable Logic Controller (PLC) (CPU, Power Module : Option Redundant)
- Gas Turbine and Generator Control
- GT start / shutdown Control
- Speed / kW / Power Factor Control
- Auto Synchronizing and Auto Sharing
- Touch Panel Operation
- Industrial Ethernet
- Remote Monitoring (Option) Graphics Monitoring
- Historical Trend & Event Logger
- Daily and Monthly Reports

M1A-17 Series Standard Package Configuration

M1A-17 Gas Turbine

- Industrial Single-Shaft
- Rotor Speed : 22,000 rpm

Compressor

- 2 Stage Centrifugal
- Pressure Ratio : 10.5 (-17, -17D)
- IGV (-17D Option)

Combustor

- Single Can Combustor
- Single Ignition
- Conventional Diffusion (-17)
- Dry Low Emission (DLE) (-17D)
- Applicable Fuel : Natural Gas, Diesel, Dual fuel

Turbine

- 3 Stage Axial Turbine

Coupling Shaft & Cover

- Flexible Coupling with Shear Pin and Cover

Reduction Gear Box

- Epicyclic
- Output Speed : 1,500 / 1,800 rpm (50/60 Hz)

Starting and Turning Motor System

- Various Frequency Drive (VFD)
- (Option : Air Starter, DC Motor)
- Turning Motor

Lube Oil System

- Lube Oil : Synthetic Ester Oil
- Turbine Driven Main Lube Pump
- Pre-Post Lube Pump
- Air Cooled Oil Cooler with Temp. Control Valve
- Water Cooled (Option)
- Integral Oil Reservoir
- Simplex Filter (Option : Duplex Type)
- Stainless Steel Piping : Down Stream of Filter

Generator

- Continuous Duty Rating
- Air Cooled Open Drip-Proof Construction
- Water Cooled (Option)
- 3 Phase, 3 Wire (Option 4 Wire)
- Standard Voltage : 0.4 kV, 3.3 kV, 6.6 kV
- Power Factor : 90% (Option 85%, 80%)
- Bearing : Ball (Roller) Bearing
- Lubrication : Grease Pack
- IEC Standard, Class F Insulation with F rise
- Exciter : Diverted Field Brushless (Option PMG)

Enclosed Package

- Carbon Steel Common Base Frame
- Outdoor Carbon Steel, Acoustic Enclosure
- Noise Level : 85 dBA at 1 m to the side of Enclosure
- Forced Ventilation Fan with Filter and Inlet Screen
- Maintenance Stage, Ladder, Beam (Option)

Intake Silencer & Filter

- Painted Carbon Steel (Outer Skin and Structure)
- 2 Stage Filter with Insect Screen
- Pulse Self Cleaning Filter (Option)
- Noise Level : 85 dBA in front of Filter

Exhaust Silencer and Stack (Option)

- Controls
- Microprocessor Based Programmable Logic Controller (PLC) (CPU, Power Module : Option Redundant)
- Gas Turbine and Generator Control
- GT start / shutdown Control
- Speed / kW / Power Factor Control
- Auto Synchronizing and Auto Sharing
- Touch Panel Operation
- Industrial Ethernet
- Remote Monitoring (Option) Graphics Monitoring
- Historical Trend & Event Logger
- Daily and Monthly Reports

GPB17 Typical Package Outlook : m (Reference)

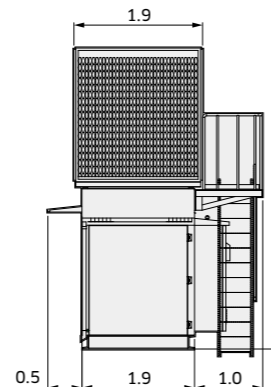
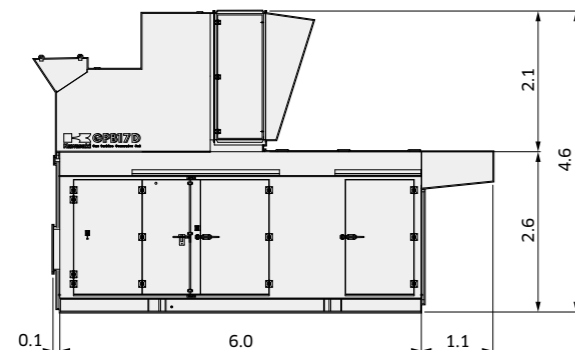

GPB17 Typical Layout : m (Reference)

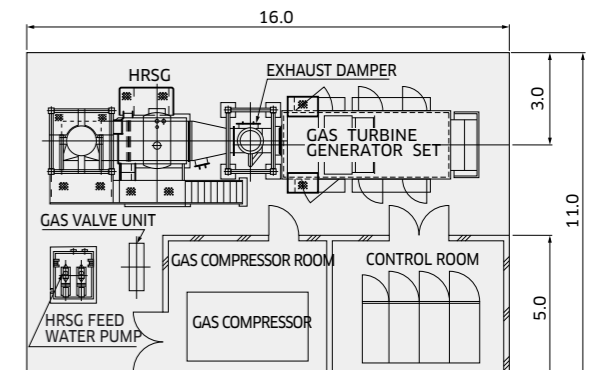
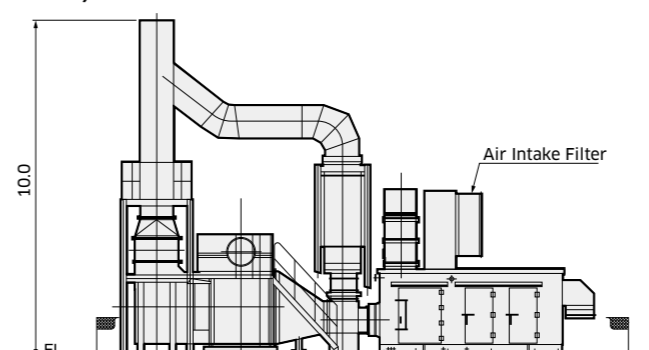

M5A Series Gas Turbine Generator Specifications

Site Condition for Normal Perfor

Elevation above sea level : 0 m
 Inlet Air Temperature : 15 °C
 Inlet Air Pressure Loss : 0.98 kPa
 Exhaust Gas Pressure Loss : 2.94 kPa
 LHV of Natural Gas Fuel : 35.9 MJ/Nm³
 (100% CH₄)

Typical Steam Condition

Steam Pressure : 0.83 MPaG
 Steam Temperature (Saturated) : 177 °C
 Feed Water Temperature : 80 °C
 Blowdown from HRSG : 0 %

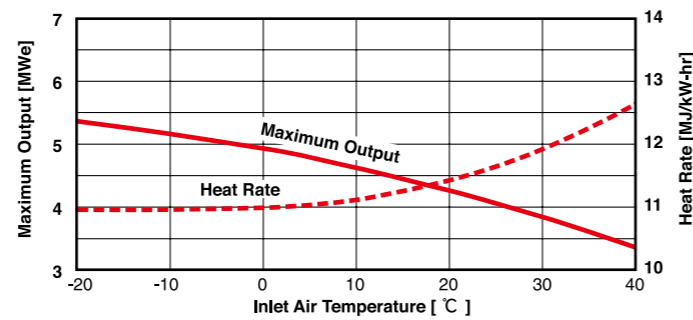

M5A Gas Turbine Series				
Gas Turbine Model	M5A-01D			
Gas Turbine Generator Model	GPB50D			
Partial Load @ AT 15 °C	%	100	75	50
Electric Output	kWe	4,450	3,340	2,225
Heat Rate	kJ/kWe-hr	11,266	12,502	16,775
Exhaust Gas Temperature	°C	505	533	528
Exhaust Gas Mass Flow	x10 ³ kg/hr	62.1	51.1	51.5
HRSG Steam Output (Typical*1)	x10 ³ kg/hr	9.3	9.1	9.0
Total Thermal Efficiency	%	77.2	82.0	80.3
Inlet Air Temperature	°C	0	15	40
Maximum Continuous Electric Output	kWe	4,930	4,450	3,360
Heat Rate	kJ/kWe-hr	10,993	11,266	12,648
Exhaust Gas Temperature	°C	495	505	538
Exhaust Gas Mass Flow	x10 ³ kg/hr	66.2	62.1	52.9
HRSG Steam Output (Typical*1)	x10 ³ kg/hr	10.3	9.3	9.3
Total Thermal Efficiency	%	79.1	77.2	81.9

M5A Series Standard Package Configuration

M5A Gas Turbine
 - Industrial Single-Shaft
 - Rotor Speed : 18,000 rpm

Compressor
 - 11 Stage Axial Flow
 - IGV & 3 Stage VSV

Combustor
 - 6 Can Combustors
 - Dual Ignition System
 - Conventional Diffusion
 - Dry Low Emission (DLE)
 - Applicable Fuel : Natural Gas

Turbine
 - 3 Stage Axial Turbine

Coupling Shaft & Cover
 - Flexible Coupling with Shear Pin and Cover

Reduction Gear Box
 - Parallel Shaft

Starting and Turning System

- Various Frequency Drive (VFD)

Lube Oil System

- Lube Oil : Turbine Oil ISO VG46 (optional VG32)
 - Turbine Driven Main Lube Oil Pump
 - Pre-Post Lube Oil Pump
 - Emergency Lube Oil Pump
 - Air Cooled Oil Cooler with Temp. Control Valve
 - Oil Reservoir integrated with Baseplate : 1,500 liter
 - Carbon Steel Piping
 - Filter
 - Oil Vapor Fan

Generator

- Continuous Duty Rating
 - 3 Phase, 3 Wire (Option 4 Wire)
 - Voltage : 6.6 kV, 11.0 kV
 - Power Factor : 90% (Option 85%, 80%)
 - IEC Standard, Class F Insulation with F rise
 - Exciter : Brushless PMG

Enclosed Package

- Carbon Steel Common Base Frame
 - Painted Carbon Steel Acoustic Enclosure
 - Noise Level : 85 dBA at 1 m to the side of Enclosure
 - Forced Ventilation Fan with Filter
 - Maintenance Stage, Ladder, Beam (Option)

Intake Silencer & Filter

- Painted Carbon Steel (Outer Skin and Structure)
 - Stainless Steel Inner Punching Metal Sheet
 - 3 Stage Filter with Insect Screen
 - Pulse Type Self Cleaning Filter (Option)
 - Noise Level : 85 dBA at 1 m to Filter inlet

Exhaust Silencer Stack (Option)

Controls
 - Microprocessor Based Programmable Logic Controller (PLC)
 (CPU, Power Module : Option Redundant)
 - Gas Turbine and Generator Control
 GT start / Shutdown Control
 Speed / kW / Power Factor Control
 Auto Synchronizing and Auto Sharing
 - Touch Panel Operation
 - Serial Link User Interface (Option)
 - SCADA System (Option)
 - Redundant Control System (Option)
 - Remote Monitoring (Option)
 Graphics Monitoring
 Historical Trend & Event Logger
 Daily and Monthly Reports

■ GPB50D Typical Package Outlook : m (Reference)

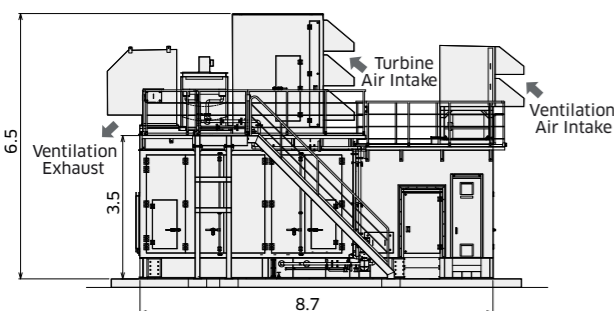

■ GPB50D Typical Layout : m (Reference)

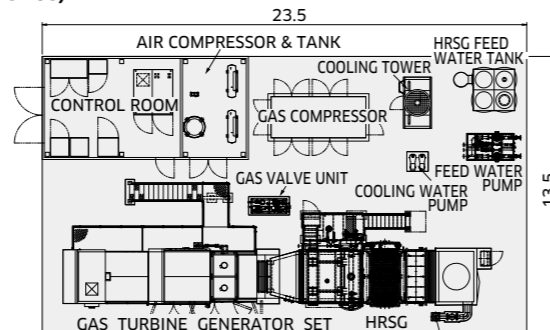

M7A Series Gas Turbine Generator Specifications

Site Condition for Normal Perfor

Elevation above sea level : 0 m
 Inlet Air Temperature : 15 °C
 Inlet Air Pressure Loss : 0.98 kPa
 Exhaust Gas Pressure Loss : 2.94 kPa (GPB80/80D)
 LHV of Natural Gas Fuel (100% CH₄) : 35.9 MJ/Nm³

Typical Steam Condition

Steam Pressure : 0.83 MPaG
 Steam Temperature (Saturated) : 177 °C
 Feed Water Temperature : 80 °C
 Blowdown from HRSG : 0 %

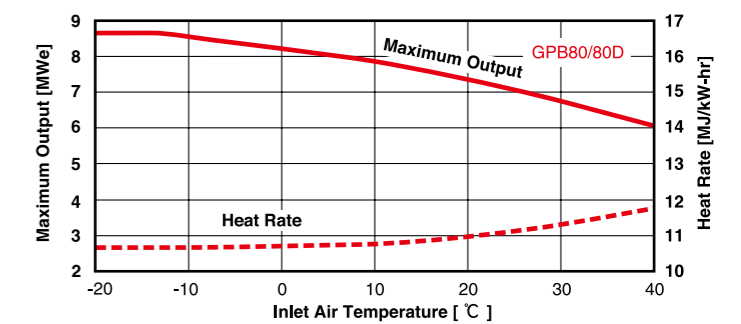

M7A Gas Turbine Series							
Gas Turbine Model	M7A-03			M7A-03D			
Gas Turbine Generator Model	GPB80			GPB80D			
Partial Load @ AT 15 °C	%	100	75	50	100	75	50
Electric Output	kWe	7,660	5,740	3,830	7,660	5,740	3,830
Heat Rate	kJ/kWe-hr	10,830	11,630	13,580	10,830	11,780	14,230
Exhaust Gas Temperature	°C	525	448	379	525	516	563
Exhaust Gas Mass Flow	x10 ³ kg/hr	97.3	97.0	96.8	97.3	84.3	66.4
HRSG Steam Output (Typical*1)	x10 ³ kg/hr	17.0	13.1	9.7	17.0	14.4	13.1
Total Thermal Efficiency	%	83.1	78.8	71.9	83.1	82.6	83.8
Inlet Air Temperature	°C	0	15	40	0	15	40
Maximum Continuous Electric Output	kWe	8,220	7,660	6,040	8,220	7,660	6,040
Heat Rate	kJ/kWe-hr	10,690	10,830	11,780	10,690	10,830	11,780
Exhaust Gas Temperature	°C	519	525	554	519	525	554
Exhaust Gas Mass Flow	x10 ³ kg/hr	101.1	97.3	84.0	101.1	97.3	84.0
HRSG Steam Output (Typical*1)	x10 ³ kg/hr	17.2	17.0	16.3	17.2	17.0	16.3
Total Thermal Efficiency	%	81.5	83.1	86.3	81.5	83.1	86.3

M7A Series Standard Package Configuration

M7A Gas Turbine
 - Industrial Single-Shaft
 - Rotor Speed : 13,790 rpm (-03/-03D)

Compressor
 - 11 Stage Axial Flow (-03/-03D)
 - Inlet Guide Vane (IGV) & 3 Stage Various Stator Vane
 - Pressure Ratio : 16 : 1 (-03/-03D)

Combustor
 - 6 Can Combustors
 - Dual Ignition System
 - Conventional Diffusion (-03)
 (Option De-NOx : Steam Injection Type)
 - Dry Low Emission (DLE) (-03D)
 - Applicable Fuel : Natural Gas, Diesel (-03/-03D)
 * Notes : Diesel is only for standby use with -03/-03D

Turbine
 - 4 Stage Axial Turbine

Coupling Shaft & Cover
 - Flexible Coupling with Shear Pin and Cover

Reduction Gear Box

- Epicyclic
 - Output Speed : 1,500 / 1,800 rpm (50/60 Hz)

Starting and Turning System
 - Various Frequency Drive (VFD)

Lube Oil System

- Lube Oil : Turbine Oil ISO VG32 (VG46 : Tropical)
 - Turbine Driven Main Lube Pump
 - Pre-Post Lube Pump
 - Emergency Lube Pump
 - Air Cooled Oil Cooler with Temp. Control Valve
 - Water Cooled (Option)
 - Integral Oil Reservoir : 2,750 liter
 - Oil Heater (Cold Weather Option)
 - Simplex Filter (Duplex Filter : Option)
 - Oil Vapor Fan

Generator

- Continuous Duty Rating
 - Air Cooled Open Drip-Proof Construction
 Water Cooled (Option)
 - 3 Phase, 3 Wire (Option 4 Wire)
 - Standard Voltage : 3.3 kV, 6.6 kV, 11.0 kV
 - Power Factor : 90% (Option 85%, 80%)
 - Bearing : Sleeve Type, Oil Bath Lubrication
 - Exciter : Diverted Field Brushless (Option PMG)

Enclosed Package

- Carbon Steel Common Base Frame
 - Outdoor Carbon Steel Acoustic Enclosure
 - Noise Level : 85 dBA at 1 m to the side of Enclosure
 - Ventilation Fan with Filter and Inlet Screen
 - Maintenance Stage, Ladder, Beam (Option)

Intake Silencer & Filter

- 3 Stage Filter with Insect Screen
 - Pulse Type Self Cleaning Filter (Option)
 - Noise Level : 85 dBA in front of Filter

Exhaust Silencer Stack (Option)

Controls
 - Microprocessor Based Programmable Logic Controller (PLC)
 (CPU, Power Module : Option Redundant)
 - Gas Turbine and Generator Control
 GT start / shutdown Control
 Speed / kW / Power Factor Control
 Auto Synchronizing and Load Sharing
 - Touch Panel Operation
 - Serial Link User Interface (Option)
 - Remote Monitoring (Option)
 Graphics Monitoring
 Historical Trend & Event Logger
 Daily and Monthly Reports

■ GPB80 Typical Package Outlook : m (Reference)

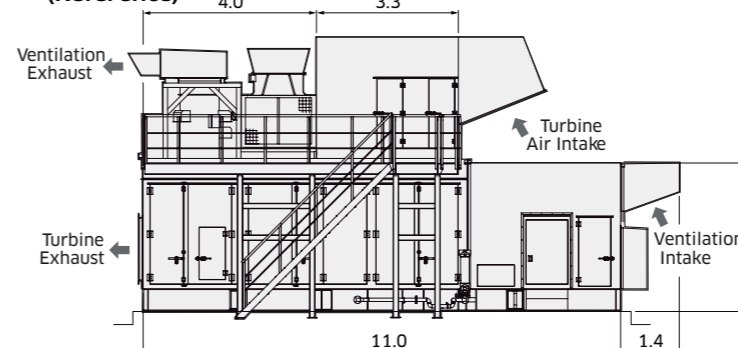

■ GPB80 Typical Layout : m (Reference)

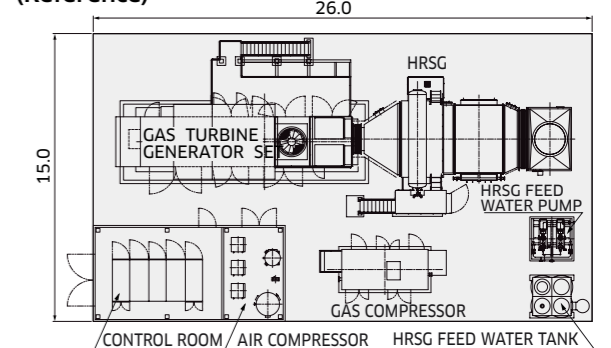

L20A Series Gas Turbine Generator Specifications

Site Condition for Normal Perfor

Elevation above sea level : 0 m
 Inlet Air Temperature : 15 °C
 Inlet Air Pressure Loss : 0.98 kPa
 Exhaust Gas Pressure Loss : 3.43 kPa (GPB180/180D)
 LHV of Natural Gas Fuel : 35.9 MJ/Nm³
 (100% CH₄)

Typical Steam Condition

Steam Pressure : 0.83 MPaG
 Steam Temperature (Saturated) : 177 °C
 Feed Water Temperature : 80 °C
 Blowdown from HRSG : 0 %

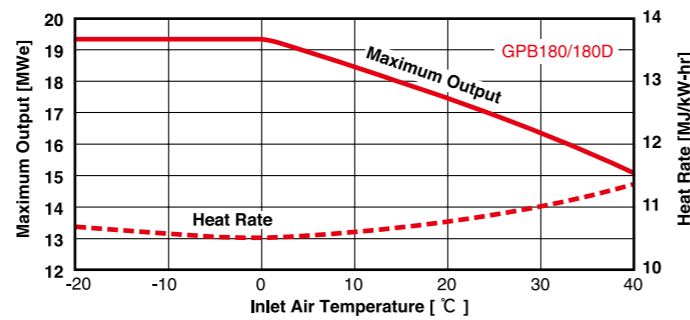

Gas Turbine Model	L20A Gas Turbine Series			
	L20A			
Gas Turbine Generator Model	GPB180 / 180D			
Partial Load @ AT 15 °C	%	100	75	50
Electric Output	kWe	17,970	13,470	8,980
Heat Rate	kJ/kWe-hr	10,690	11,510	13,200
Exhaust Gas Temperature	°C	545	517	443
Exhaust Gas Mass Flow	x10 ³ kg/hr	213	188	182
HRSG Steam Output (Typical*1)	x10 ³ kg/hr	39.7	32.5	24.5
Total Thermal Efficiency	%	84.0	82.4	77.7
Inlet Air Temperature	°C	0	15	40
Maximum Continuous Electric Output	kWe	19,320	17,970	15,080
Heat Rate	kJ/kWe-hr	10,500	10,690	11,380
Exhaust Gas Temperature	°C	538	545	565
Exhaust Gas Mass Flow	x10 ³ kg/hr	221	213	193
HRSG Steam Output (Typical*1)	x10 ³ kg/hr	40.2	39.7	38.8
Total Thermal Efficiency	%	82.5	84.0	86.7

L20A Series Standard Package Configuration

- L20A Gas Turbine**
 - Industrial Single-Shaft
 - Rotor Speed : 9,420 rpm
- Compressor**
 - 11 Stage Axial Flow
 - IGV & 4 Stage VSV
- Combustor**
 - 8 Can Combustors
 - Dual Ignition System
 - Conventional Diffusion (GPB180) (Option De-NOx : Steam Injection)
 - Dry Low Emission (DLE) (GPB180D)
 - Applicable Fuel : Natural Gas, Diesel (Standby Only) Dual Fuel
- Turbine**
 - 3 Stage Axial Turbine
- Coupling Shaft & Cover**
 - Flexible Coupling with Shear Pin and Cover
- Reduction Gear Box**
 - Parallel Shaft

Starting and Turning System

- Various Frequency Drive (VFD)

Lube Oil System

- Lube Oil : Turbine Oil ISO VG32 (optional VG46)
- Turbine Driven Main Lube Oil Pump
- Pre-Post Lube Oil Pump
- Emergency Lube Oil Pump
- Water Cooled Oil Cooler with Temp. Control Valve
- Oil Reservoir integrated with Baseplate : 5,900 liter
- Stainless Steel Piping : Down Stream of Filter
- Filter
- Oil Vapor Fan

Generator

- Continuous Duty Rating
- 3 Phase, 3 Wire (Option 4 Wire)
- Voltage : 6.6 kV, 11.0 kV
- Power Factor : 90% (Option 85%, 80%)
- IEC Standard, Class F Insulation with F rise
- Exciter : Brushless PMG

Enclosed Package

- Carbon Steel Common Base Frame
- Painted Carbon Steel Acoustic Enclosure
- Noise Level : 85 dBA at 1 m to the side of Enclosure
- Forced Ventilation Fan with Filter
- Maintenance Stage, Ladder, Beam (Option)

Intake Silencer & Filter

- Painted Carbon Steel (Outer Skin and Structure)
- Stainless Steel Inner Punching Metal Sheet
- 3 Stage Filter with Insect Screen
- Pulse Type Self Cleaning Filter (Option)
- Noise Level : 85 dBA at 1 m to Filter inlet

Exhaust Silencer Stack (Option)

- Controls**
 - Microprocessor Based Programable Logic Controller (PLC) (CPU, Power Module : Option Redundant)
 - GT Turbine and Generator Control
 - GT start / Shutdown Control
 - Speed / kW / Power Factor Control
 - Auto Synchronizing and Auto Sharing
 - Touch Panel Operation
 - Serial Link User Interface (Option)
 - SCADA System (Option)
 - Redundant Control System (Option)
 - Remote Monitoring (Option)
 - Graphics Monitoring
 - Historical Trend & Event Logger
 - Daily and Monthly Reports

■ GPB180 Typical Package Outlook : m (Reference)

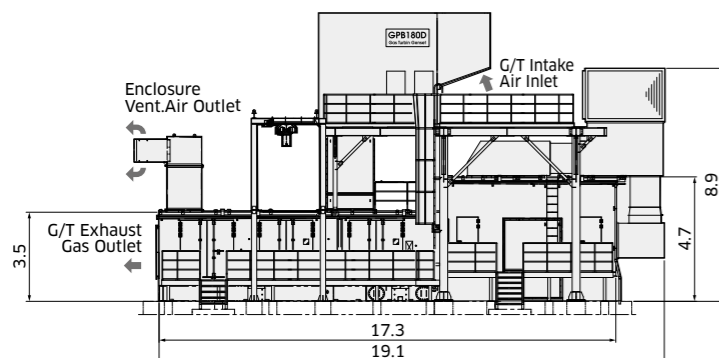

■ GPB180 Typical Layout : m (Reference)

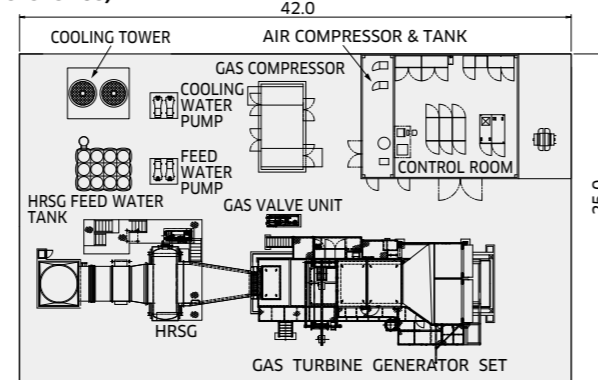

L30A Series Gas Turbine Generator Specifications

Site Condition for Normal Perfor

Elevation above sea level : 0 m
 Inlet Air Temperature : 15 °C
 Inlet Air Pressure Loss : 0.98 kPa
 Exhaust Gas Pressure Loss : 3.43 kPa (GPB300/300D)
 LHV of Natural Gas Fuel : 35.9 MJ/Nm³
 (100% CH₄)

Typical Steam Condition

Steam Pressure : 0.83 MPaG
 Steam Temperature (Saturated) : 177 °C
 Feed Water Temperature : 80 °C
 Blowdown from HRSG : 0 %

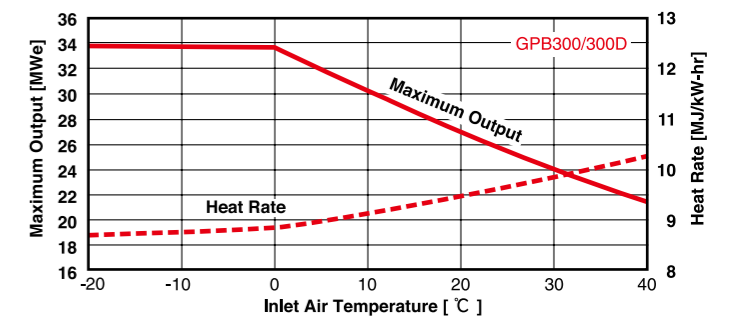

Gas Turbine Model	L30A Gas Turbine Series			
	L30A			
Gas Turbine Generator Model	GPB300 / 300D			
Partial Load @ AT 15 °C	%	100	75	50
Electric Output	kWe	32,360	24,270	16,180
Heat Rate	kJ/kWe-hr	9,196	9,845	11,879
Exhaust Gas Temperature	°C	509	482	491
Exhaust Gas Mass Flow	x10 ³ kg/hr	324.7	289.6	252.4
HRSG Steam Output (Typical*1)	x10 ³ kg/hr	53.8	44.3	40.0
Total Thermal Efficiency	%	83.2	81.8	81.0
Inlet Air Temperature	°C	0	15	40
Maximum Continuous Electric Output	kWe	34,120	32,360	24,660
Heat Rate	kJ/kWe-hr	8,963	9,196	10,117
Exhaust Gas Temperature	°C	475	509	550
Exhaust Gas Mass Flow	x10 ³ kg/hr	345.3	324.7	272.2
HRSG Steam Output (Typical*1)	x10 ³ kg/hr	50.9	53.8	52.0
Total Thermal Efficiency	%	80.8	83.2	86.4

L30A Series Standard Package Configuration

- L30A Gas Turbine**
 - Industrial Twin-Shaft
 - Power Turbine Rotor Speed : 5,600 rpm
- Compressor**
 - 14 Stage Axial Flow
 - IGV & 4 Stage VSV
- Combustor**
 - 8 Can Combustors
 - Dual Ignition System
 - Conventional Diffusion (GPB300) (Option De-NOx : Steam Injection)
 - Dry Low Emission (DLE) (GPB300D)
 - Applicable Fuel : Natural Gas
- Turbine**
 - Gas Generator Turbine : 2 Stage Axial Turbine
 - Power Turbine : 3 Stage Axial Turbine
- Coupling Shaft & Cover**
 - Flexible Coupling with Shear Pin and Cover (Reduction Gear and Generator connection)
- Reduction Gear Box**
 - Parallel Shaft

Starting and Turning System

- Various Frequency Drive (VFD)

Lube Oil System

- Lube Oil : Turbine Oil ISO VG32 (optional VG46)
- Motor Driven Main Lube Oil Pump
- Standby Lube Oil Pump
- Pre-Post Lube Oil Pump
- Emergency Lube Oil Pump
- Water Cooled Oil Cooler with Temp. Control Valve
- Oil Reservoir integrated with Baseplate : 11,700 liter
- Stainless Steel Piping : Down Stream of Filter
- Duplex Full-flow Filter
- Oil Vapor Fan

Generator

- Continuous Duty Rating
- 3 Phase, 3 Wire (Option 4 Wire)
- Voltage : 11 kV
- Power Factor : 90% (Option 85%, 80%)
- IEC Standard, Class F Insulation with F rise
- Exciter : Brushless PMG

Enclosed Package

- Carbon Steel Common Base Frame
- Painted Carbon Steel Acoustic Enclosure
- Noise Level : 85 dBA at 1 m to the side of Enclosure
- Forced Ventilation Fan with Filter
- Maintenance Stage, Ladder, Beam (Option)

Intake Silencer & Filter

- Painted Carbon Steel (Outer Skin and Structure)
- Stainless Steel Inner Punching Metal Sheet
- 3 Stage Filter with Insect Screen
- Pulse Type Self Cleaning Filter (Option)
- Noise Level : 85 dBA at 1 m to Filter inlet

Exhaust Silencer Stack (Option)

- Controls**
 - Microprocessor Based Programable Logic Controller (PLC) (CPU, Power Module : Option Redundant)
 - Gas Turbine and Generator Control
 - GT start / Shutdown Control
 - Speed / kW / Power Factor Control
 - Auto Synchronizing and Auto Sharing
 - Touch Panel Operation
 - Serial Link User Interface (Option)
 - SCADA System (Option)
 - Redundant Control System (Option)
 - Remote Monitoring (Option)
 - Graphics Monitoring
 - Historical Trend & Event Logger
 - Daily and Monthly Reports

■ GPB300 Typical Package Outlook : m (Reference)

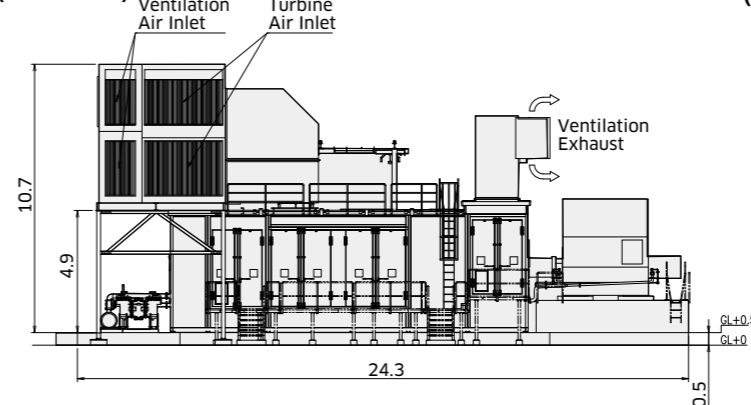

■ GPB300 Typical Layout : m (Reference)

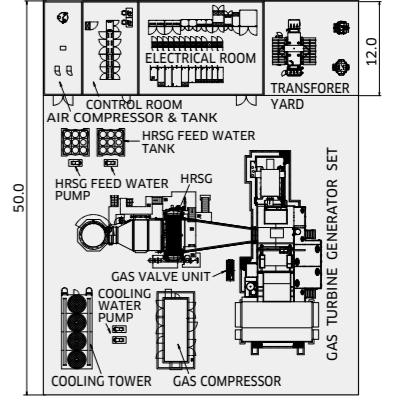

Standby Model Introduction

Excellent Features of Kawasaki Standby Gas Turbine Generator Sets

Kawasaki has installed over 7,000 Standby Gas Turbine Generator Sets rated from 200 kVA to 6,000 kVA worldwide. The reliability of Kawasaki Standby Gas Turbine Generator Sets has allowed to install in Internet Data Centers, Hospitals, and Key Facilities where uninterrupted power is certainly required.

- High Performance, and very reliable, with the low cost gas turbine solution
- Easy Maintenance
- Dual Fuel Capability
- Low Noise Operation
- Low Vibration
- No Cooling Water
- High Starting Reliability, and quick start
- Light Weight, and space saving, easy transportation and installation
- Clean Exhaust Gas
- Excellent frequency control, even with large step loads

● Example of GPS2000 System Configuration for Indoor Installation

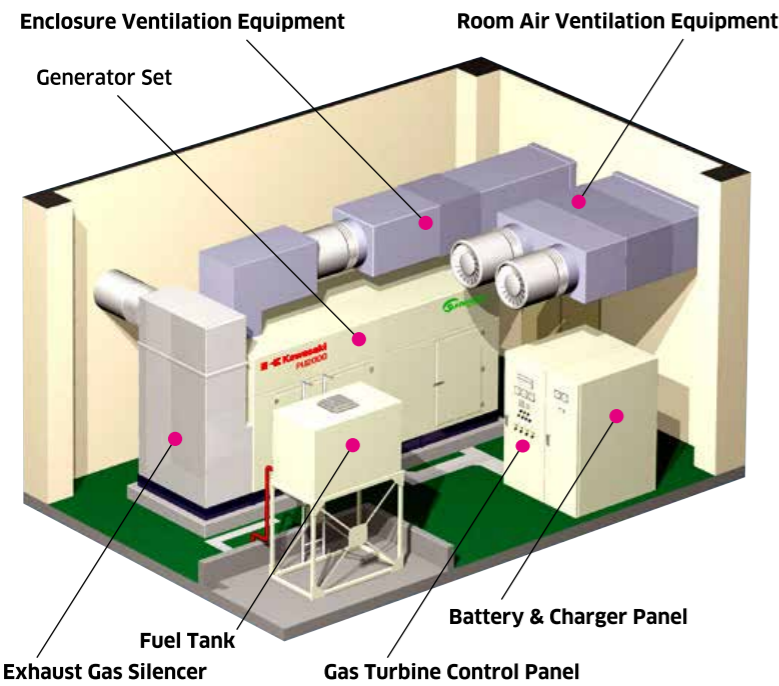

● Typical Standby / Gas Turbine Generator Layout

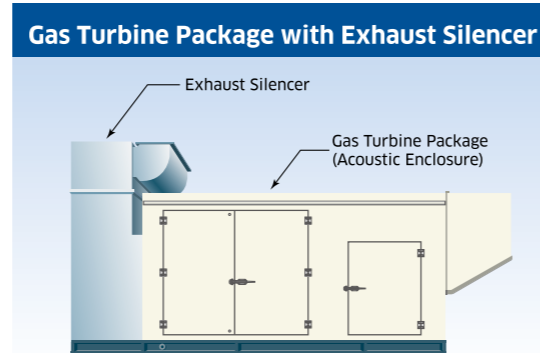

Internal View of Gas Turbine Package

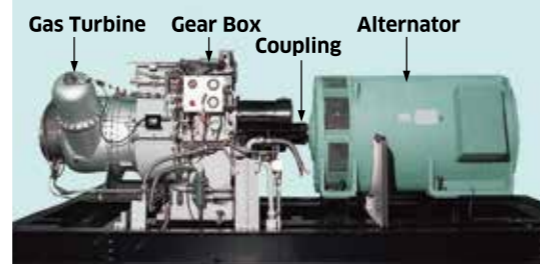

Standby Model (GPS Series)

Standby generator sets must start and supply power in the event of the loss of power from the utility. These functions depend greatly on the prime-mover of the standby system. Starting and providing power are often more important than financial conditions such as the initial cost of equipment. Kawasaki standby GPS Series are suitable for standby power supply when utility power fails. All the models are designed for automatic operation (start/power supply/stop) and equipped with alarm/protection systems.

Basic Specifications

Item	GPS750	GPS1250	GPS1500	GPS2000	GPS2500	GPS3000	GPS4000	GPS5000	GPS6000
Generator Set									
*1 Electric Output (kW)	600	1,000	1,200	1,600	2,000	2,400	3,200	4,000	4,800
Starting Time	Within 40-sec.								
Load Application Capacity	100% (Resistive load)								
Freq. Deviation	Within ± 4.5% (with 100% block load on and off)								
Transient	Within ± 5.0%								
Steady State	Within ± 0.3%								
Fuel Type	Kerosene, Diesel, Gas (option)								
*2 Fuel Consumption (liter / hr)	305	525	620	695	1,065	1,245	1,390	1,835	2,050
Gas Turbine									
Turbine Model	S2A-01	M1A-01	M1A-03	M1A-23	M1T-01S	M1T-03	M1T-23	M1T-33A	M1T-33
Type	Heavy-duty, simple open cycle, single-shaft								
Turbine Speed (rpm)	22,000								
Output Speed (rpm)	1,500 (50 Hz), 1,800 (60 Hz)								
Dry Weight (ton)	1.48	3.0	3.5	5.7	6.4	13.5			
Lube Oil Type / Brand	Synthetic oil / Shell ASTO-500, Mobil jet II, Castrol AERO 5000, DP BPTO 2380								
Lube Oil Tank Capacity (approx.L)	66	100	210	160	240	360			
Lube Oil Consumption (liter / hr)		0.08		0.16		0.2			
Alternator									
Type	3-phase, open screen-protected, brushless, self-ventilated, synchronous								
Output (kVA)	750	1,250	1,500	2,000	2,500	3,000	4,000	5,000	6,000
Voltage Regulation	Within ± 2.5% (steady state from no-load to full-load, at pf = 0.8)								
Excitation System	Brushless by A.C. exciter and rotating diodes								
*3 Standard Voltage	6.6kV								
Starting System									
Electrical start with D.C. motors (Optional: Pneumatic start with air turbines)									
Type of Batteries									
Valve Regulated Lead-Acid (VRLA) Battery									
Generator Set Dimension (Indoor Type)									
Length (m)	4.0	4.9	5.4	5.8	6.2	7.7			
Width (m)	1.6	1.7	1.8	2.5	3.0	3.6			
Height (m)	2.1	2.5	2.6	2.9	3.6	3.6			
Weight (ton)	6.8	10.5	11.4	14.7	19.7	24.6	36.6	39.0	
Noise Level at 1m									
From Package	Approx. 85dBA in open air (optional system: 80~70dBA)								
From Exhaust Silencer Outlet	Approx. 90dBA (optional system: 85~65 dBA at 1 m with a secondary silencer)								

(Note) * 1 : Output : Up to 40°C of ambient temp., 150 m above sea level.
 * 2 : Fuel Consumption : At full load, 15°C, using diesel fuel, allowance is 5%.
 Diesel Oil : Density 0.83 g/cm³, LHV 42,700 kJ/kg
 * 3 : Other voltage is available as option.

● Typical Timing Chart Of Operation

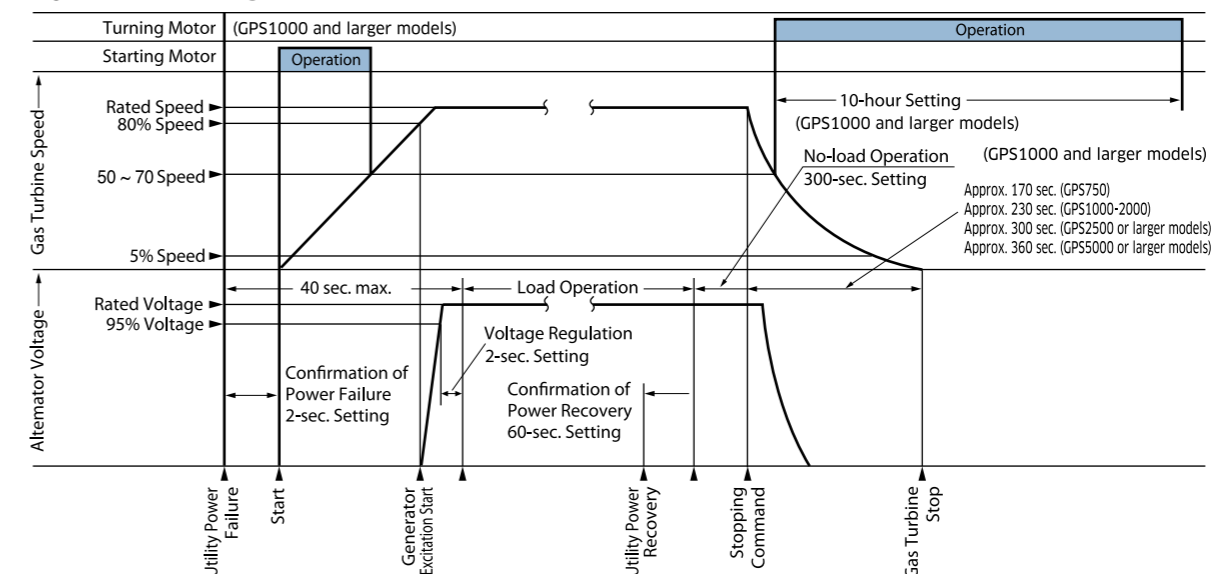

99.9% Start-up Reliability!

The Great East Japan Earthquake (Mar.11, 2011)

On March 11, 2011, the earthquake with 7.9 on the Richter scale hit the East Japan area, causing a blackout that hit about 3 million households in this area. In the area of the blackout, 1,034 units out of 1,035 successfully worked.

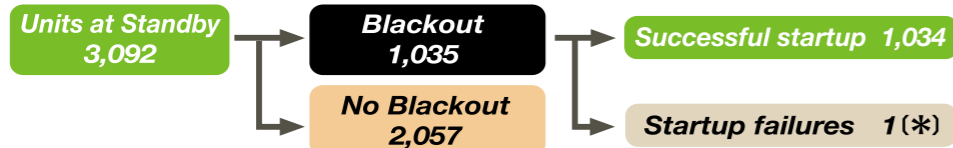

(*) Due to improper maintenance by its owner.



Mobile / Trailer Model (MGP / TGP Series)

Kawasaki MGP/TGP Series are gas turbine generators mounted on trucks or trailers for mobile application. MGP/TGP integrate all necessary equipment and enable fully automatic operation without the need for external power supply. High durability against vibration and shock, and reliable operation are important for this application. Kawasaki MGP/TGP is designed to fully meet such demands.

Advantages

1. Developed with Vast Field Experience

Gas Turbines on trucks or trailers need to withstand large vibration/shock when the trucks run on roads. Kawasaki meets mobile installation condition with gas turbines experience and technology from Kawasaki aircraft jet engines operating under similar severe environmental conditions.

2. Low Center of Gravity and Large Tumble-down Angle

Thanks to light weight of gas turbines, the center of gravity of MGP/TGP is low, and this makes it possible to have stable maneuverability.

3. Compact Integration

MGP/TGP incorporate all necessary equipment, including fuel tank, batteries, exhaust silencer, cable reel, etc., inside a compact aluminum enclosure. This feature enables easy maintenance.

4. Blackout Start Capability

MGP/TGP can start up and supply electricity without any external utility supply, such as electric power and fuel.

● MGP Series Generator Set

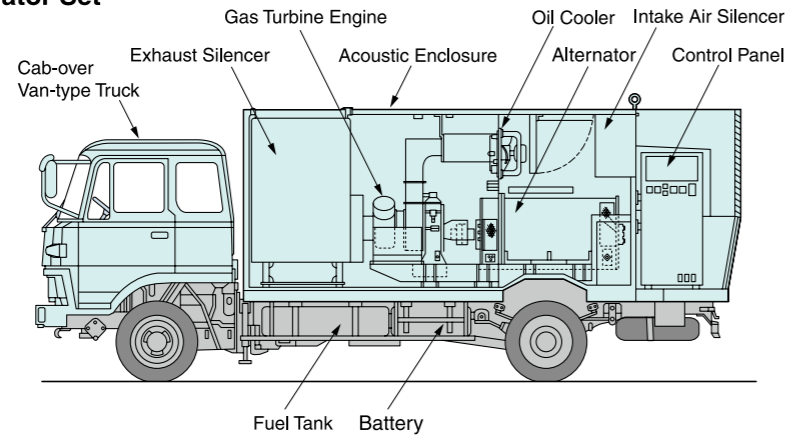

● TGP Series Generator Set

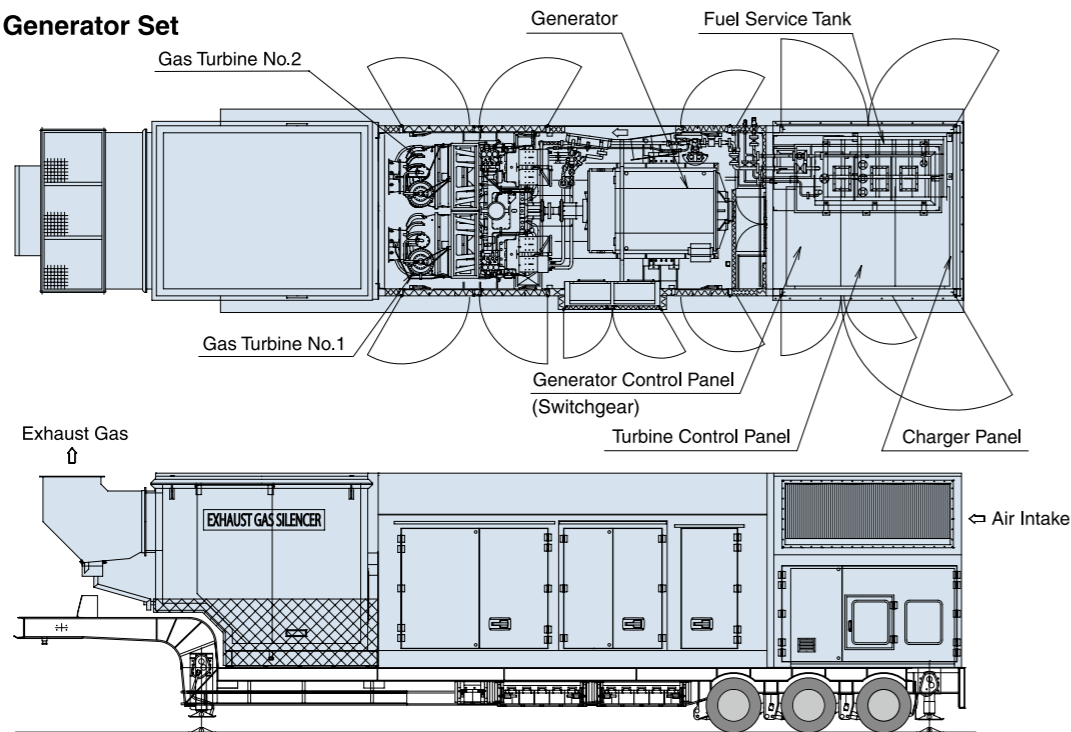

Basic Specifications

Item	Model	MGP 750	MGP 1000	MGP 1250	MGP 1500	MGP 2000	TGP 2500	TGP 3000	TGP 4000
*1 Output (kW) 40°C		600	800	1000	1,200	1,600	2,000	2,400	3,200
Fuel		Kerosene, Diesel							
Generator Sets	Load Application Allowance	100% (Resistance Load)							
	Freq. Deviation Transient	Within ± 4.5% (with 100% block load on and off)							
	Steady State	Within ± 0.3%							
Fuel Consumption (l/h)	Kerosene	320	490	555	655	735	1,125	1,310	1,465
	Diesel Oil	305	465	525	620	695	1,065	1,245	1,390
Truck / Trailer	Type	Truck				Trailer			
	Dimensions	11.0		12.0		9.9 (not including cockpit)			
	Including			2.5					
	Truck			3.4		3.6			
	Max. Height (m)								
Total Weight (ton)		Less than 20 tons	Less than 22 tons			Less than 25 tons	Less than 33 tons		
Noise Level at 1 m (dBA)		85							

(Note)

* 1 : Output : Up to 40°C of ambient temp., 150 m above sea level.

Installation Example



TGP3000



MGP1250



MGP2000



MGP2000

Kawasaki Techno-Net

● Full Time Support

● Maintenance Management

- Predictive services based on trending data and asset maintenance management
- What to do* *When to do it* *How to do it* *Who's to do it*

● Improvement of Availability and Quality of Maintenance

- Minimum down time and good quality with adequate maintenance strategies and execution.

● Remote Maintenance System by a GT Expert

- Proven effectiveness by most Kawasaki remote maintenance users
- Fleet wide analysis

Techno-Net system continuously monitors the Gas Turbine Plant in any region of the world

Three main features of Techno-Net system

Global remote monitoring	Preventing serious failures	Maintenance management
Remote monitoring through the internet	Enforced monitoring and diagnosis	Adequate management of maintenance

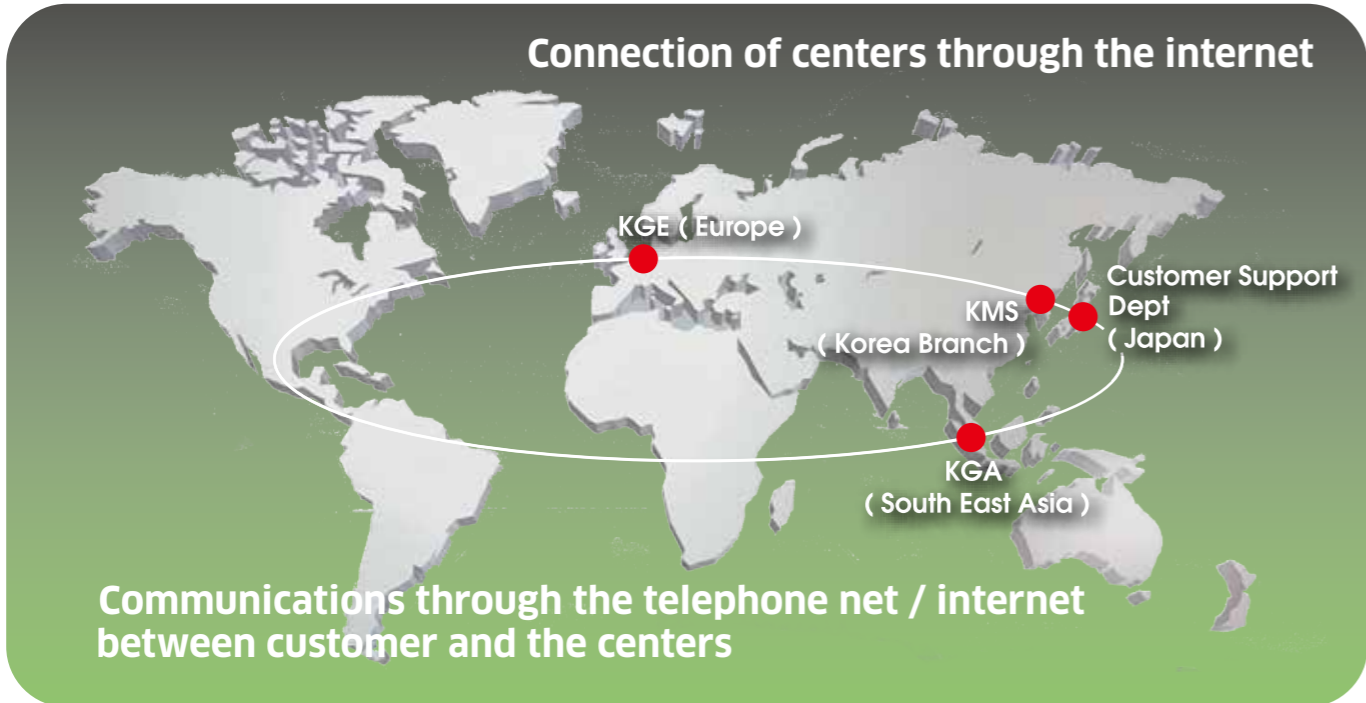

Internet / Intranet

- The Kawasaki World Business Center in the USA, Germany, Malaysia, China, Korea and Japan are connected by the Internet and by the KHI intranet to monitor gas turbines remotely and globally.

Attended monitoring

- All system data is monitored and recorded hourly, as well as all start signals and first out malfunction signals.
- Predictive and preventative maintenance is accomplished by analysis of thermal cycles and unit vibration.

Installation Examples



Kawasaki Gas Turbine has been installed to....

- Data Center
- Paper Mill
- Hospital
- Food Process
- College Campus
- Oil & Gas
- Tire Manufacturer
- District Heat & Cooling
- AND MORE !!!**

In 2010 Kawasaki accumulated 10,000th Kawasaki Gas Turbine Engines in all over the world !!!

